

INSTALLATION AND MAINTENANCE INSTRUCTIONS

4SCU14LE SERIES

Split System Air Conditioner

Save these instructions for future reference



WARNING

The equipment covered in this manual is to be installed by trained and experienced service and installation technicians. Improper installation, modification, service, or use can cause electrical shock, fire, explosion, or other conditions which may cause personal injury, death, or property damage. Use appropriate safety gear including safety glasses and gloves when installing this equipment.



WARNING

Risk of electrical shock. Disconnect all remote power supplies before installing or servicing any portion of the system. Failure to disconnect power supplies can result in property damage, personal injury, or death.



WARNING

Installation and servicing of air conditioning equipment can be hazardous due to internal refrigerant pressure and live electrical components. Only trained and qualified service personnel should install or service this equipment. Installation and service performed by unqualified persons can result in property damage, personal injury, or death.



WARNING

Sharp metal edges can cause injury. When installing the unit, use care to avoid sharp edges.

TABLE OF CONTENTS

INSTALLATION	2
START-UP	12
OPERATION	16
MAINTENANCE	16
CONNECTION DIAGRAM	18
WARRANTY	19

Manufactured By
ALLIED AIR ENTERPRISES, INC.
A Lennox International Inc. Company
215 Metropolitan Drive
West Columbia, SC 29170



* 5 0 6 2 5 1 - 0 1 *

INSTALLATION

General

Read this entire instruction manual, as well as the instructions supplied in separate equipment, before starting the installation. Observe and follow all warnings, cautions, instructional labels, and tags. Failure to comply with these instructions could result in an unsafe condition and/or premature component failure.

These instructions are intended as a general guide only for use by qualified personnel and do not supersede any national or local codes in any way. The installation must comply with all provincial, state, and local codes as well as the National Electrical Code (U.S.) or Canadian Electrical Code (Canada). Compliance should be determined prior to installation.

4SCU14LE condensing units use R410A which is an ozone-friendly HFC refrigerant. The unit must be installed with a matching indoor coil and line set. 4SCU14LE units are designed for use in expansion valve (TXV) systems only. The TXV expansion valve must be ordered separately from the manufacturer. A filter drier approved for use with 410A is installed in the unit.

When servicing or repairing HVAC components, ensure the fasteners are appropriately tightened. Table 1 shows torque values for fasteners.

Torque Table	
Fastener	Torque
Stem Caps	8 ft. lbs.
Service Port Caps	8 ft. lbs.
Sheet Metal Screws	16 in. lbs.
#8 Machine Screws	16 in. lbs.
#10 Machine Screws	28 in. lbs.
Compressor Bolts	90 in. lbs.

Table 1

Inspection of Shipment

Upon receipt of equipment, carefully inspect it for possible shipping damage. If damage is found, it should be noted on the carrier's freight bill. Take special care to examine the unit inside the carton if the carton is damaged. Any concealed damage discovered should be reported to the last carrier immediately, preferably in writing, and should include a request for inspection by the carrier's agent.

If any damages are discovered and reported to the carrier DO NOT INSTALL THE UNIT, as claim may be denied.

Check the unit rating plate to confirm specifications are as ordered.

Location of Unit

Refer to Figure 1 for installation clearances.

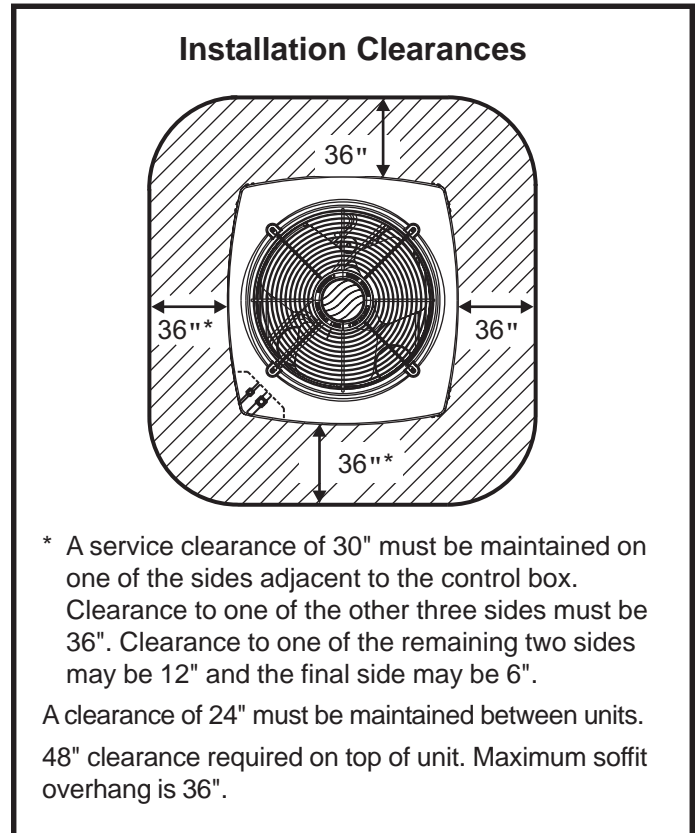

Figure 1

Slab Mounting

When installing unit at grade level, install on level slab high enough so that water from higher ground will not collect around unit (see Figure 2).

Roof Mounting

Install unit at a minimum of 4" above surface of the roof. Care must be taken to ensure weight of unit is properly distributed over roof joists and rafters. Either redwood or steel supports are recommended.

Electrical Wiring

All field wiring must be done in accordance with the National Electrical Code (NEC) recommendations, Canadian Electrical Code (CEC) and CSA Standards, or local codes, where applicable.

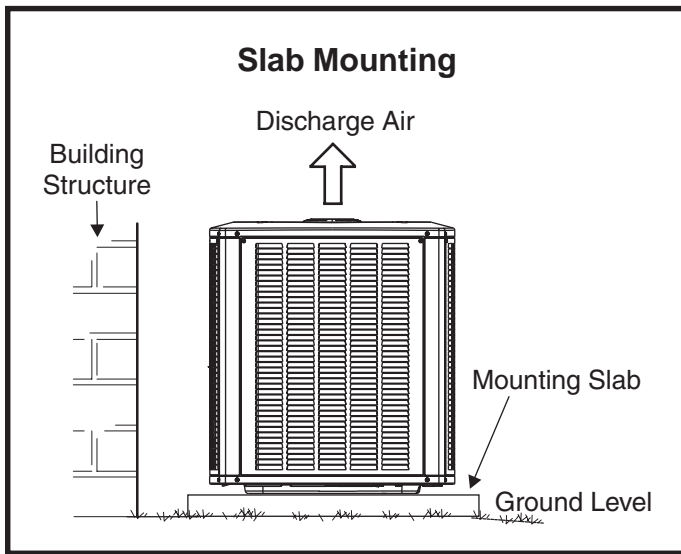

Figure 2

WARNING

Unit must be grounded in accordance with national and local codes. Failure to ground unit properly can result in personal injury or death.

Refer to the furnace or blower coil Installation Instructions for additional wiring application diagrams and refer to unit rating plate for minimum circuit ampacity and maximum overcurrent protection size.

1. Install line voltage power supply to unit from a properly sized disconnect switch. Any excess high voltage field wiring should be trimmed or secured away from the low voltage field wiring.
2. Ground unit at unit disconnect switch or to an earth ground. To facilitate conduit, a hole is in the bottom of the control box. Connect conduit to the control box using a proper conduit fitting. Units are approved for use only with copper conductors. 24V Class II circuit connections are made to the low voltage pigtailed. A complete unit wiring diagram is located inside the unit control box cover (see also page 18 of this instruction).
3. Install room thermostat on an inside wall that is not subject to drafts, direct sunshine, or other heat sources.
4. Install low voltage wiring from outdoor to indoor unit and from thermostat to indoor unit (see Figure 3).
5. Do not bundle any excess 24V control wire inside control box. Run control wire through installed wire tie and tighten wire tie to provide low voltage strain relief and to maintain separation of field-installed low and high voltage circuits.

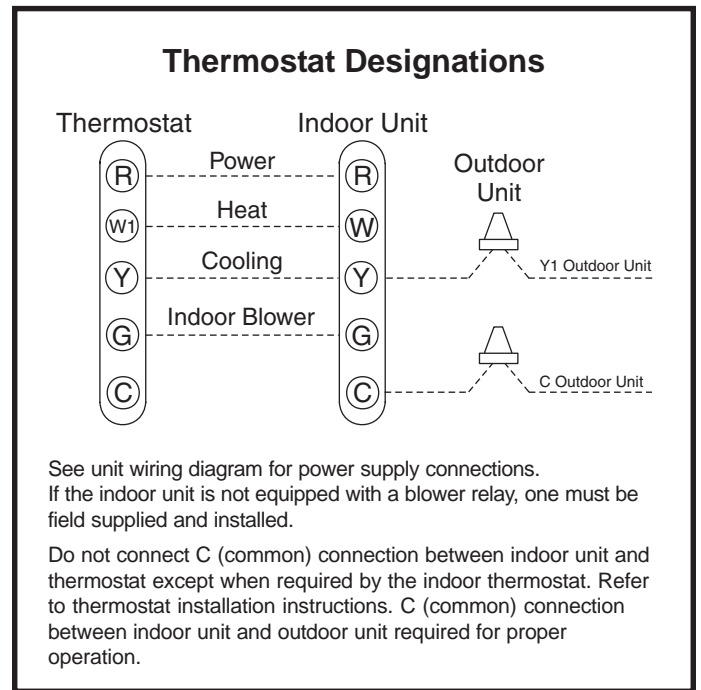

Figure 3

Refrigerant Piping

WARNING

Refrigerant can be harmful if inhaled. Refrigerant must always be used and recovered responsibly. Incorrect or irresponsible use of refrigerant can result in personal injury or death.

If the 4SCU14LE unit is being installed with a new indoor coil and line set, the refrigerant connections should be made as outlined in this section. If an existing line set and/or indoor coil will be used to complete the system, refer to this section as well as the section that follows entitled **Flushing Existing Line Set and Indoor Coil**.

If this unit is being matched with an approved line set or indoor coil which was previously charged with R22 refrigerant, the line set and coil must be flushed prior to installation. If the unit is being used with an existing indoor coil which was equipped with a liquid line which served as a metering device (RFCI), the liquid line must be replaced prior to the installation of the 4SCU14LE unit.

Field refrigerant piping consists of liquid and suction lines from the outdoor unit (sweat connections) to the indoor coil (flare or sweat connections).

Select line set diameters from Table 2 on page 4 to ensure that oil returns to the compressor. Size vertical suction riser

to maintain minimum velocity at minimum capacity. Recommended line length is 50' or less. If more than 50' line set is required, contact Technical Services at 1-800-448-5872.

Table 2 shows the diameters for line sets up to 100' although vertical lift applications and trapping requirements need to be reviewed with Technical Services for line sets over 50'.

Refrigerant Line Set Diameters (in.)					
Liquid Line					
BTUH	Line Set Length and Size				
	12 ft.	25 ft.	50 ft.	75 ft.	100 ft.
18,000	3/8	3/8	3/8	3/8	3/8
24,000	3/8	3/8	3/8	3/8	3/8
30,000	3/8	3/8	3/8	3/8	1/2
36,000	3/8	3/8	3/8	3/8	1/2
41,000	3/8	3/8	3/8	1/2	1/2
42,000	3/8	3/8	3/8	1/2	1/2
47,000	3/8	3/8	3/8	1/2	1/2
48,000	3/8	3/8	3/8	1/2	1/2
60,000	3/8	3/8	3/8	1/2	1/2

Suction Line					
BTUH	Line Set Length and Size				
	12 ft.	25 ft.	50 ft.	75 ft.	100 ft.
18,000	3/4	3/4	3/4	3/4	3/4
24,000	3/4	3/4	3/4	3/4	7/8
30,000	3/4	3/4	3/4	7/8	7/8
36,000	7/8	7/8	7/8	7/8	1-1/8
41,000	7/8	7/8	7/8	7/8	1-1/8
42,000	7/8	7/8	7/8	1-1/8	1-1/8
47,000	7/8	7/8	7/8	1-1/8	1-1/8
48,000	7/8	7/8	7/8	1-1/8	1-1/8
60,000	1-1/8	1-1/8	1-1/8	1-1/8	1-1/8

For installations exceeding 50', contact Technical Services at 1-800-448-5872.

Table 2

Installing Refrigerant Line

During the installation of an air conditioning system, it is important to properly isolate the refrigerant line to prevent unnecessary vibration. Line set contact with the structure (wall, ceiling, or floor) may cause objectionable noise when vibration is translated into sound. As a result, more energy or vibration can be expected. Close attention to line set isolation must be observed. If refrigeration lines are routed through a wall, seal and isolate the opening so vibration is not transmitted to the building.

Following are some points to consider when placing and installing a high-efficiency outdoor unit:

Placement

Be aware that some localities are adopting sound ordinances based on how noisy the unit is at the neighbor's home, not at the original installation. Install the unit as far as possible from the property line. When possible, do not install the unit directly outside a bedroom window. Glass has a very high level of sound transmission. Figure 4 shows how to place the outdoor unit and line set to reduce line set vibration.

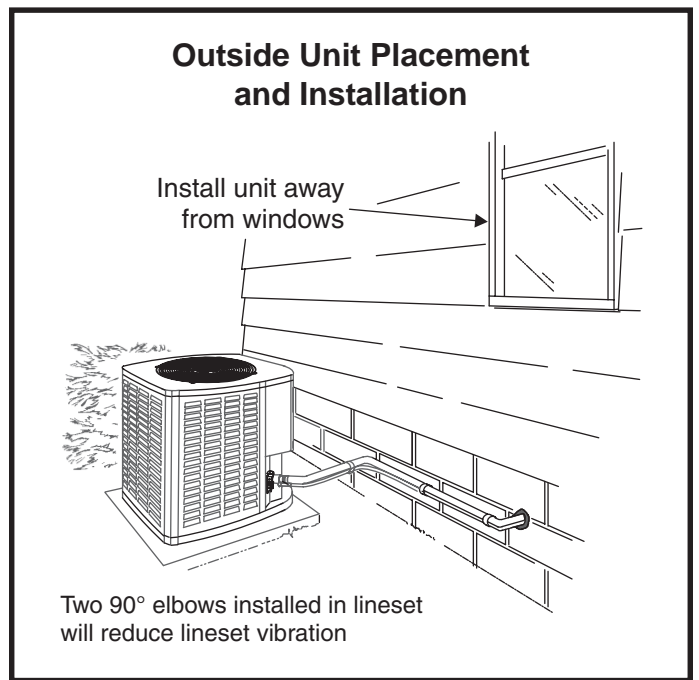

Figure 4

Line Set Isolation

Illustrations on the following pages demonstrate procedures which ensure proper refrigerant line set isolation. Figure 5 shows how to install line sets on horizontal runs. Figure 6 shows how to make a transition from horizontal to vertical and Figure 7 on page 6 shows how to install line sets on vertical runs.

Refrigerant Line Sets: Installing Horizontal Runs

To hang line set from joist or rafter, use either metal strapping material or anchored heavy nylon wire ties.

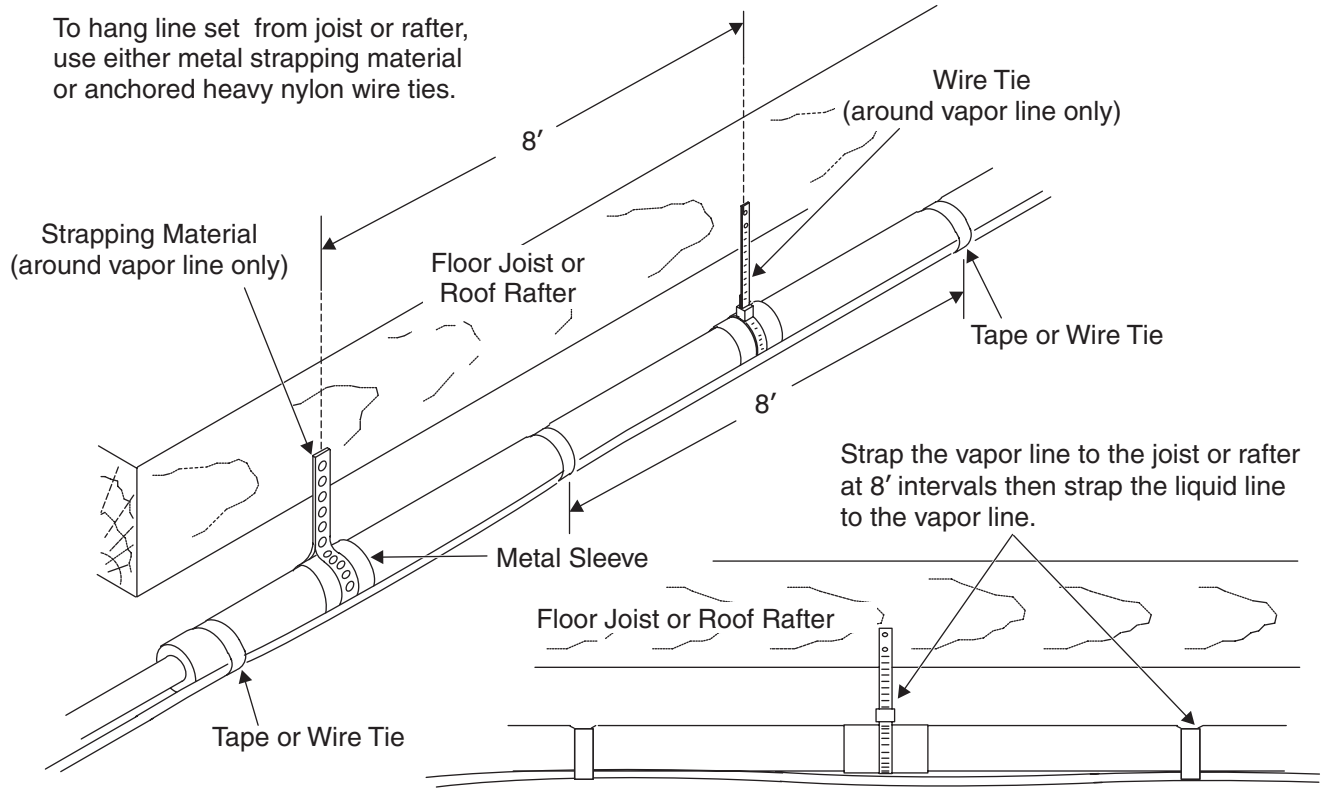

Figure 5

Refrigerant Line Sets: Transition from Vertical to Horizontal

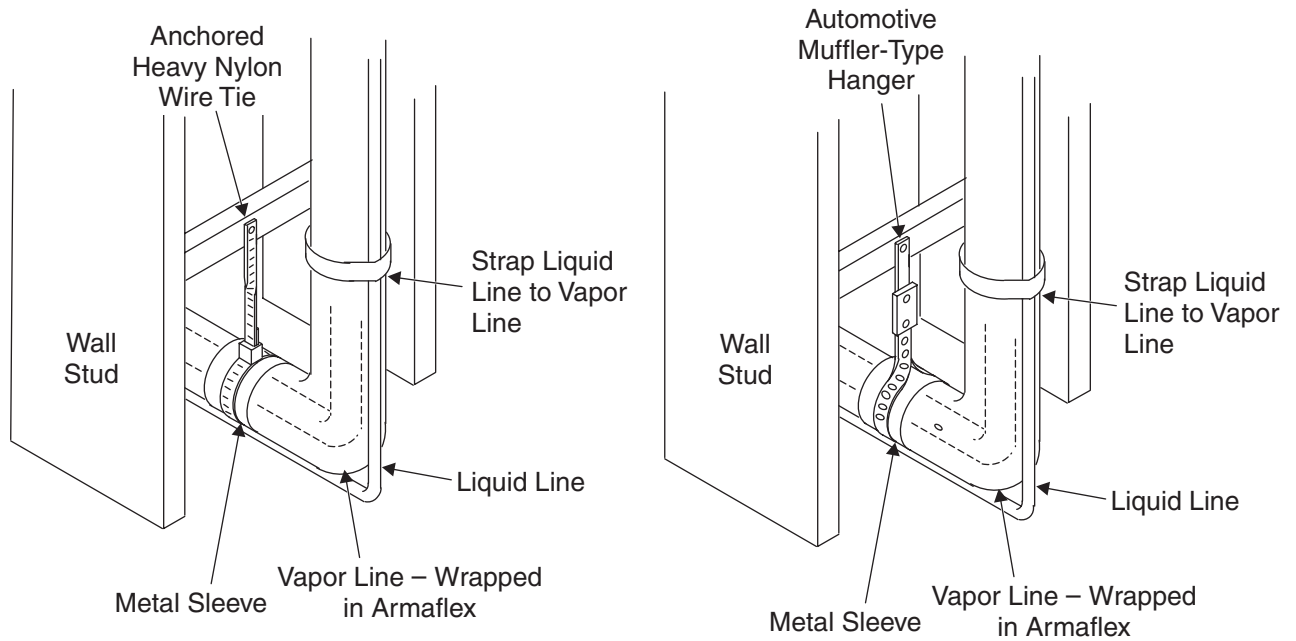

Figure 6

Refrigerant Line Sets: Installing Vertical Runs (new construction shown)

NOTE: Similar installation practices should be used if line set is to be installed on exterior of outside wall.

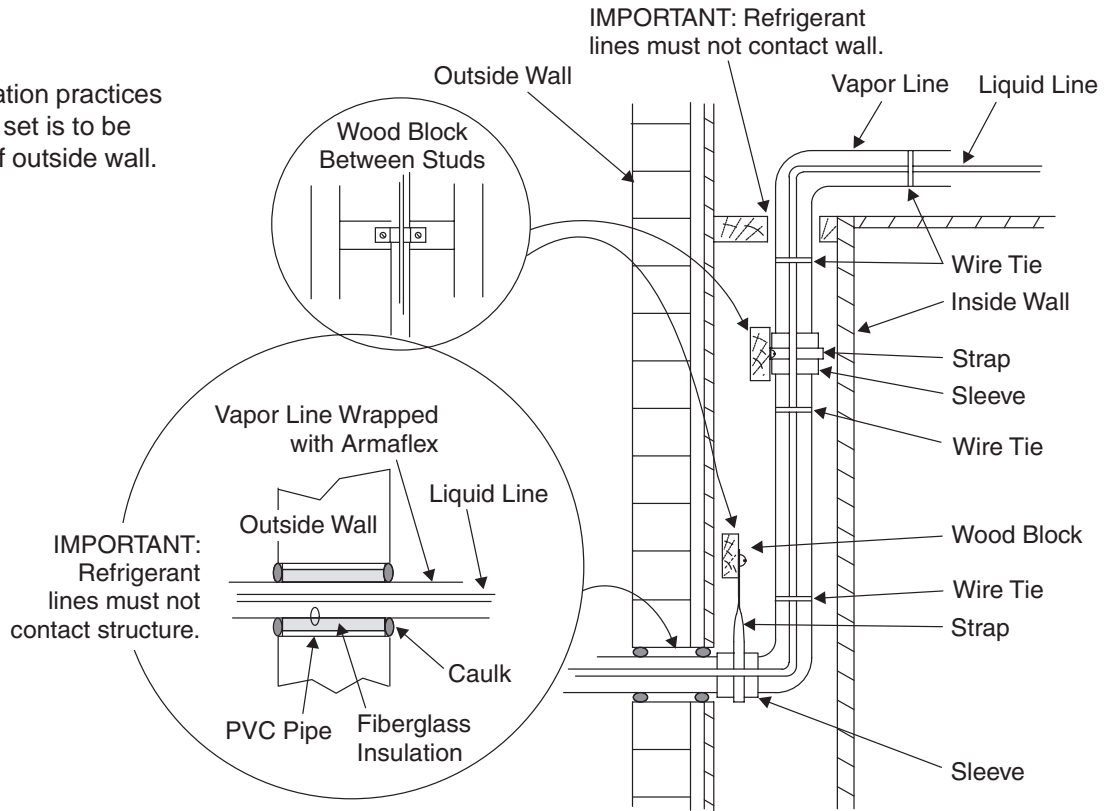

Figure 7

Brazing Connection Procedure

1. Install a thermal expansion valve kit (sold separately) that is approved for use with R410A refrigerant in the liquid line at the indoor coil. Install the equalizer port from the kit in the suction line.
2. Cut ends of refrigerant lines square (free from nicks or dents). Deburr the ends. The pipe must remain round; do not pinch end of line.
3. Before making line set connections, use dry nitrogen to purge the refrigerant piping. This will help to prevent oxidation and the introduction of moisture into the system.
4. Use silver alloy brazing rods (5% or 6% silver alloy for copper-to-copper brazing or 45% silver alloy for copper-to-brass or copper-to-steel brazing) which are rated for use with R410A refrigerant.
5. Remove the Schrader core assemblies before brazing to protect them from damage due to extreme heat. Replace the cores when brazing is complete.
6. Remove light maroon washers from service valves and shield light maroon stickers to protect them during brazing. Wrap a wet cloth around the valve body and copper tube stub to protect it from heat damage.
7. Braze the line set to the service valve. Quench the joints with water or a wet cloth to prevent heat damage to the valve core and opening port. **The tube end must stay bottomed in the fitting during final assembly to ensure proper seating, sealing, and rigidity.**

WARNING

Polyolester (POE) oils used with R410A refrigerant absorb moisture very quickly. It is very important that the refrigerant system be kept closed as much as possible. **DO NOT** remove line set caps or service valve stub caps until ready to make connections.

Flushing Existing Line Set and Indoor Coil

This procedure should not be performed on systems which contain contaminants, such as compressor burn out.

CAUTION

When flushing existing line set and/or indoor coil, be sure to empty all existing traps. Residual mineral oil can act as an insulator, preventing proper heat transfer. It can also clog the thermal expansion valve, reducing system performance and capacity. Failure to properly flush system as explained in these instructions will void warranty.

Required Equipment

The following equipment is needed to flush the existing line set and indoor coil (see Figure 8): Two clean R22 recovery bottles, an oil-less recovery machine with a “pump down” feature, and two sets of gauges (one for use with R22 and one for use with R410A).

Flushing Procedure

IMPORTANT: The line set and/or indoor coil must be flushed with at least the same amount of refrigerant that previously charged the system. Check the charge in the flushing cylinder before flushing the unit.

1. Remove existing R22 refrigerant using the appropriate procedure.

*If the existing outdoor unit is not equipped with shutoff valves, or if the unit is not operational AND the **existing** R22 refrigerant will be used to flush the system:*

Disconnect all power to the existing outdoor unit. Connect the existing unit, a clean recovery cylinder, and the recovery machine according to the instructions provided with the recovery machine. Remove all R22 refrigerant from the existing system. Refer to the gauges after shutdown to confirm that the entire system is completely void of refrigerant. Disconnect the liquid and suction lines from the existing outdoor unit.

*If the existing outdoor unit is equipped with manual shutoff valves AND **new** R22 refrigerant will be used to flush the system:*

Start the existing R22 refrigerant system in cooling mode and close the liquid line valve. Pump all the existing R22 refrigerant back into the outdoor unit.

(It may be necessary to bypass the low pressure switches to ensure complete refrigerant evacuation.)

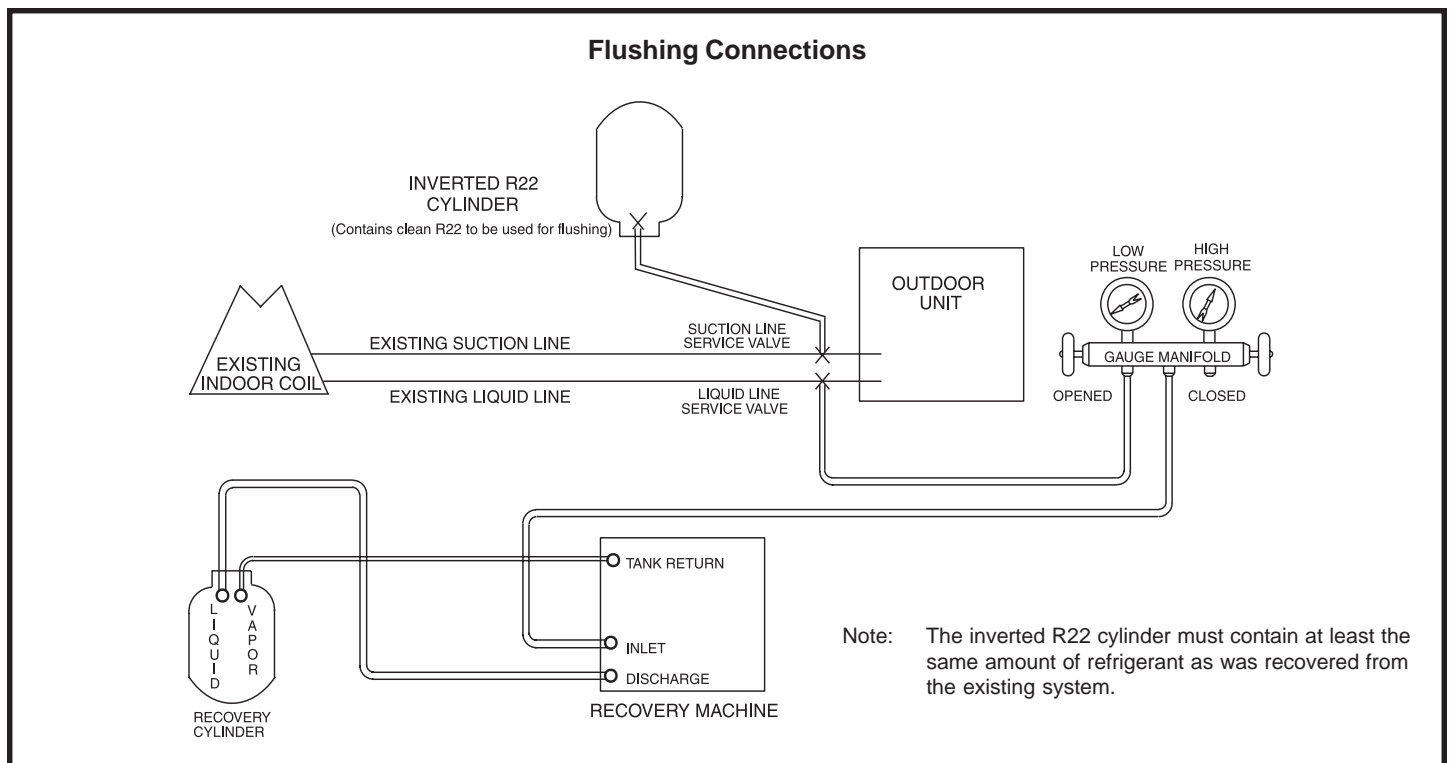

Figure 8

When the low side system pressures reach 0 psig, close the suction line valve. Disconnect all power to the existing outdoor unit. Refer to the gauges after shutdown to confirm that the valves are not allowing refrigerant to flow back into the low side of the system. Disconnect the liquid and suction lines from the existing outdoor unit.

2. Remove the existing outdoor unit. Set the new R410A unit and follow the brazing connection procedure outlined previously on this page to make line set connections. **Do not install the R410A thermal expansion valve at this time.**
 3. Make low voltage and line voltage connections to the new outdoor unit. **Do not turn on power to the unit or open the outdoor unit service valves at this time.**
 4. Remove the existing R-22 refrigerant flow control orifice or thermal expansion valve before continuing with flushing procedures. R-22 flow control devices are not approved for use with R410A refrigerant and may prevent proper flushing. Use a field-provided fitting to reconnect the lines.
 5. Remove the pressure tap valve cores from the 4SCU14LE unit's service valves. Connect an R-22 cylinder with clean refrigerant to the suction service valve. Connect the R-22 gauge set to the liquid line valve and connect a recovery machine with an empty recovery tank to the gauge set.
 6. Set the recovery machine for liquid recovery and start the recovery machine. Open the gauge set valves to allow the recovery machine to pull a vacuum on the existing system line set and indoor coil.
 7. Invert the cylinder of clean R-22 and open its valve to allow liquid refrigerant to flow into the system through the suction line valve. Allow the refrigerant to pass from the cylinder and through the line set and the indoor coil before it enters the recovery machine.
 8. After all of the liquid refrigerant has been recovered, switch the recovery machine to vapor recovery so that all of the R-22 vapor is recovered. Allow the recovery machine to pull a vacuum on the system.
- NOTE:** A single system flush should remove all of the mineral oil from the existing refrigerant lines and indoor coil. A second flushing may be done (using clean refrigerant) if insufficient amounts of mineral oil were removed during the first flush. **After each system flush, allow the recovery machine to pull a vacuum on the system at the end of the procedure.**
9. Close the valve on the inverted R22 cylinder and the gauge set valves. Pump the remaining refrigerant out

of the recovery machine and turn the machine off.

10. Use nitrogen to break the vacuum on the refrigerant lines and indoor coil before removing the recovery machine, gauges, and R22 refrigerant drum. Re-install pressure tap valve cores into the 4SCU14LE unit's service valves.
11. Install a thermal expansion valve kit (sold separately) that is approved for use with R410A refrigerant in the liquid line at the indoor coil.

Refrigerant Metering Device

4SCU14LE units are designed for use with TXV systems only.

Expansion valves equipped with Chatleff-type fittings are available from the manufacturer. See Table 3 for proper TXV for each unit.

TXV Data	
Model	Part Number
4SHP14LE-18, -24, -30	H4TXV01
4SHP14LE-36, -41, -42, -47, -48	H4TXV02
4SHP14LE-48, -60	H4TXV03

Table 3

To install an expansion valve (see Figure 9):

1. Separate the distributor assembly and remove the piston orifice and used teflon seal. Insert nozzle end of the expansion valve along with a new teflon seal into the distributor and tighten to 20 – 30 ft. lbs. Use backup wrench on all wrench flats. **Overtightening will crush the teflon seal and may cause a leak.**
2. Attach liquid line portion of distributor assembly along with new teflon seal to the inlet of the expansion valve. Tighten to 20 – 30 ft. lbs. Use backup wrench on all wrench flats. **Overtightening will crush the teflon seal and may cause a leak.**
3. Connect the external equalizer line to the equalizer port on the suction line and tighten to 8 ft. lbs.
4. Strap the superheat sensing bulb to the suction header.

If installing an expansion valve on an indoor coil that previously used a fixed orifice, be sure to remove the existing fixed orifice. Failure to remove a fixed orifice when installing an expansion valve to the indoor coil will result in improper operation and damage to the system.

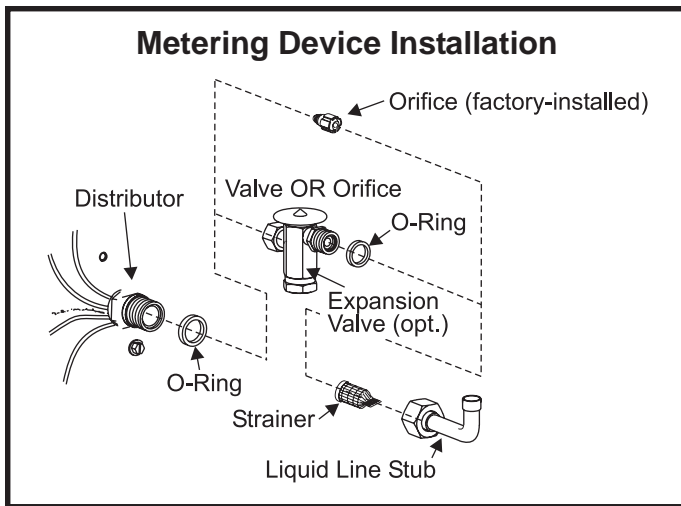

Figure 9

Manifold Gauge Set

Manifold gauge sets used with systems charged with R410A refrigerant must be capable of handling the higher system operating pressures. The gauges should be rated for use with pressures 0 – 800 on the high side and a low side of 30" vacuum to 250 psi with dampened speed to 500 psi. Gauge hoses must be rated for use at up to 800 psi of pressure with a 4000 psi burst rating.

Liquid and Suction Line Service Valves

The liquid line and suction line service valves and service ports are used for leak testing, evacuating, charging, and checking charge.

Each valve is equipped with a service port which has a factory-installed Schrader valve (see Figure 10). A service port cap protects the Schrader valve from contamination and serves as the primary leak seal.

To Access the Schrader Port:

1. Remove the service port cap with an adjustable wrench.
2. Connect gauge to the service port.
3. When testing is completed, replace service port cap. Tighten finger tight, then an additional 1/6 turn.

To Open Liquid or Suction Line Service Valve:

1. Remove stem cap with an adjustable wrench.
2. Use a service wrench with a hex-head extension to back the stem out counterclockwise as far as it will go. Use a 3/16" hex head extension for liquid line service valves and a 5/16" extension for suction line service valves.

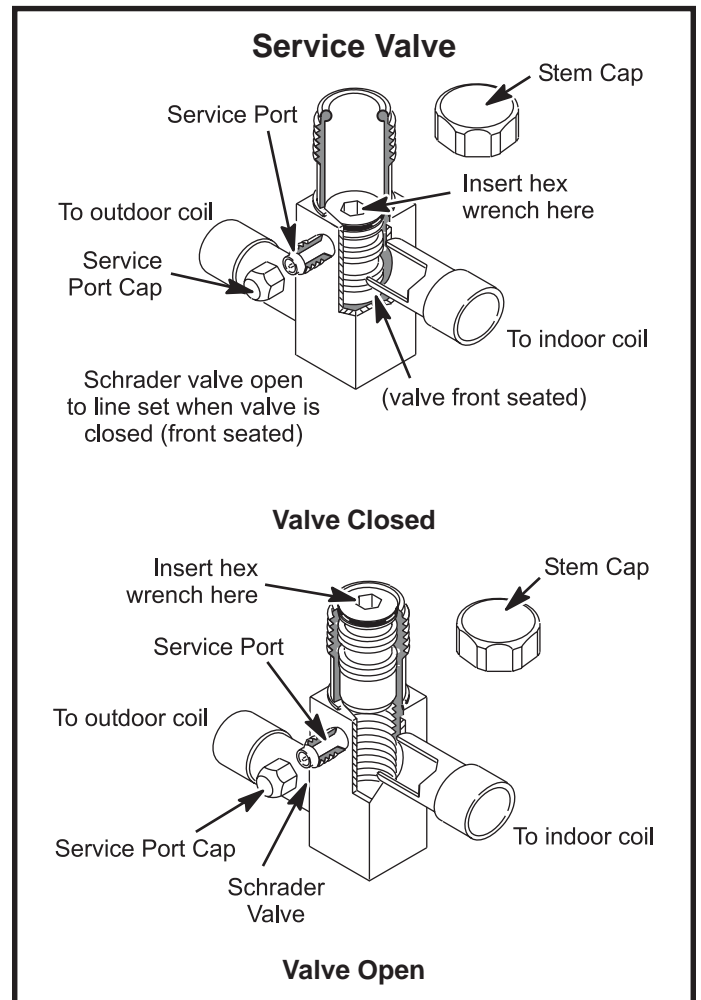

Figure 10

3. Replace the stem cap. Tighten finger tight, then tighten an additional 1/6 turn.

To Close Liquid or Suction Line Service Valve:

1. Remove the stem cap with an adjustable wrench.
2. Use a service wrench with a hex-head extension to turn the stem clockwise to seat the valve. Tighten firmly.
3. Replace the stem cap. Tighten finger tight, then tighten an additional 1/6 turn.

Suction Line (Ball Type) Service Valve

Suction line (ball type) service valves function the same way as the other valves; the difference is in the construction (see Figure 11).

Evacuation

Evacuating the system of noncondensables is critical for proper operation of the unit. Noncondensables are defined as any gas that will not condense under temperatures and pressures present during operation of an air conditioning system. Noncondensables and water vapor combine with refrigerant to produce substances that corrode copper piping and compressor parts.

Use a thermocouple or thermistor electronic vacuum gauge that is calibrated in microns. Use an instrument that reads down to 50 microns.



Do not use a compressor to evacuate a system. Avoid deep vacuum operation. Extremely low vacuums can cause internal arcing and compressor failure. Danger of equipment damage. Damage caused by deep vacuum operation will void warranty.

1. Connect the manifold gauge set to the service valve ports as follows:
 - Low pressure gauge to suction line service valve
 - High pressure gauge to liquid line service valve
2. Connect micron gauge.
3. Connect the vacuum pump (with vacuum gauge) to the center port of the manifold gauge set.
4. Open both manifold valves and start vacuum pump.
5. Evacuate the line set and indoor unit to a minimum of 500 microns or lower. During the early stages of evacuation, it is desirable to close the manifold gauge valve at least once to determine if there is a rapid rise in pressure. A rapid rise in pressure indicates a relatively large leak. If this occurs, the leak testing procedure must be repeated.
6. When 500 microns or lower is maintained, close the manifold gauge valves, turn off the vacuum pump, and disconnect the manifold gauge center port hose from the vacuum pump. Attach the manifold gauge center port hose to a nitrogen cylinder with pressure regulator set to 150 psig and purge the hose. Open the manifold gauge valves to break the vacuum in the line set and indoor unit. Close the manifold gauge valves.

7. Shut off the nitrogen cylinder and remove the manifold gauge hose from the cylinder. Open the manifold gauge valves to release the nitrogen from the line set and indoor unit.
8. Reconnect the manifold gauge to the vacuum pump, turn the pump on, and continue to evacuate the line set and indoor unit until 500 microns is maintained within a 20-minute period after shutting off the vacuum pump and closing the manifold gauge valves.
9. When the requirements above have been met, disconnect the manifold hose from the vacuum pump. Open the service valves to break the vacuum in the line set and indoor unit.

START-UP



If unit is equipped with a crankcase heater, it should be energized 24 hours before unit start-up to prevent compressor damage as a result of slugging.

1. Rotate fan to check for frozen bearings or binding.
2. Inspect all factory and field-installed wiring for loose connections.
3. After evacuation is complete, open liquid line and suction line service valves to release refrigerant charge (contained in outdoor unit) into system.
4. Replace the stem caps and secure finger tight, then tighten an additional 1/6 of a turn.
5. Check voltage supply at the disconnect switch. The voltage must be within the range listed on the unit nameplate. If not, do not start equipment until the power company has been consulted and the voltage condition corrected.
6. Set thermostat for cooling demand, turn on power to indoor blower and close the outdoor unit disconnect switch to start the unit.
7. Recheck unit voltage with unit running. Power must be within range shown on unit nameplate.

Refrigerant Charging

This system is charged with R410A refrigerant which operates at much higher pressures than R22. The liquid line drier provided with the unit is approved for use with R410A. Do not replace it with one designed for use with R22. **This unit is NOT approved for use with coils which use capillary tubes as a refrigerant metering device.**

R410A refrigerant cylinders are rose colored. Refrigerant should be added through the vapor valve in the liquid state.

Certain R410A cylinders are identified as being equipped with a dip tube. These allow liquid refrigerant to be drawn from the bottom of the cylinder without inverting the cylinder. Do not turn this type of cylinder upside down to draw refrigerant.

Units are factory charged with the amount of R410A refrigerant indicated on the unit rating plate. This charge is based on a matching indoor coil and outdoor coil with 15'

Refrigerant Charge Adjustment

Liquid Line Set Diameter	Oz. per 5 ft. adjust from 15 ft. line set *
3/8 in.	3 oz. per 5 ft.

* If line length is **greater than 15 ft.**, add this amount.
If line length is **less than 15 ft.**, remove this amount.

Table 4



Mineral oils are not compatible with R410A. If oil must be added, it must be a polyol ester oil.

line set. For varying lengths of line set, refer to Table 4 for refrigerant charge adjustment.

If the system is void of refrigerant, clean the system using the procedure described below.

1. Use dry nitrogen to pressurize the system and check for leaks. Repair leaks, if possible.
2. Evacuate the system to remove as much of the moisture as possible.
3. Use dry nitrogen to break the vacuum.
4. Evacuate the system again.
5. Weigh the appropriate amount of R410A refrigerant (listed on unit nameplate) into the system.
6. Monitor the system to determine the amount of moisture remaining in the oil. Use a test kit to verify that the moisture content is within the kit's dry color range. It may be necessary to replace the filter drier several times to achieve the required dryness level. **If system dryness is not verified, the compressor will fail in the future.**

The outdoor unit should be charged during warm weather. However, applications arise in which charging must occur in the colder months. The method of charging is determined by the **outdoor ambient temperature**.

Measure the liquid line temperature and the outdoor ambient temperature as outlined below:

1. Connect the manifold gauge set to the service valve ports as follows:
 - Low pressure gauge to suction line service valve

- High pressure gauge to liquid line service valve
2. Close manifold gauge set valves. Connect the center manifold hose to an upright cylinder of R410A.
 3. If room temperature is below 70°F, set the room thermostat to call for heat. This will create the necessary load for properly charging the system in the cooling cycle.
 4. Use a digital thermometer to record the outdoor ambient temperature.
 5. When the heating demand has been satisfied, switch the thermostat to cooling mode with a set point of 68°F. When pressures have stabilized, use a digital thermometer to record the liquid and suction line temperatures.
 6. The outdoor temperature will determine which charging method to use. Proceed with the appropriate charging method.

Charge Using Weigh-In Method

If the system is void of refrigerant, or if the outdoor ambient temperature is cool, first locate and repair any leaks then use the weigh-in method to charge the unit.

1. Recover the refrigerant from the unit.
2. Conduct a leak check, then evacuate as previously outlined.
3. Weigh in the charge according to the total amount shown on the unit nameplate.

If weighing facilities are not available or if unit is being charged during warm weather, follow one of the other procedures outlined below.

**Charge Using Subcooling Method –
Outdoor Temperatures 65°F or Above**

When the outdoor ambient temperature is 65°F or above, the subcooling method can be used to charge the unit.

1. With the manifold gauge hose on the liquid service port and the unit operating stably, use a digital thermometer to record the liquid line temperature.
2. At the same time, record the liquid line pressure reading.
3. Use the temperature/pressure chart (Table 5) to determine the saturation temperature for the liquid line pressure reading.
4. Subtract the liquid line temperature from the saturation temperature (according to the chart) to determine

Temp. °F	Pressure Psig	Temp. °F	Pressure Psig	Temp. °F	Pressure Psig
32	100.8	74	214.0	116	396.0
33	102.9	75	217.4	117	401.3
34	105.0	76	220.9	118	406.7
35	107.1	77	224.4	119	412.2
36	109.2	78	228.0	120	417.7
37	111.4	79	231.6	121	423.2
38	113.6	80	235.3	122	428.8
39	115.8	81	239.0	123	434.5
40	118.0	82	242.7	124	440.2
41	120.3	83	246.5	125	445.9
42	122.6	84	250.3	126	451.8
43	125.0	85	254.1	127	457.6
44	127.3	86	258.0	128	463.5
45	129.7	87	262.0	129	469.5
46	132.2	88	266.0	130	475.6
47	134.6	89	270.0	131	481.6
48	137.1	90	274.1	132	487.8
49	139.6	91	278.2	133	494.0
50	142.2	92	282.3	134	500.2
51	144.8	93	286.5	135	506.5
52	147.4	94	290.8	136	512.9
53	150.1	95	295.1	137	519.3
54	152.8	96	299.4	138	525.8
55	155.5	97	303.8	139	532.4
56	158.2	98	308.2	140	539.0
57	161.0	99	312.7	141	545.6
58	163.9	100	317.2	142	552.3
59	166.7	101	321.8	143	559.1
60	169.6	102	326.4	144	565.9
61	172.6	103	331.0	145	572.8
62	175.5	104	335.7	146	579.8
63	178.5	105	340.5	147	586.8
64	181.6	106	345.3	148	593.8
65	184.3	107	350.1	149	601.0
66	187.7	108	355.0	150	608.1
67	190.9	109	360.0	151	615.4
68	194.1	110	365.0	152	622.7
69	197.3	111	370.0	153	630.1
70	200.6	112	375.1	154	637.5
71	203.9	113	380.2	155	645.0
72	207.2	114	385.4		
73	210.6	115	390.7		

Table 5

- _____ ° Saturation Temperature °F
- _____ ° Liquid Line Temperature °F
- = _____ ° Subcooling Value °F

subcooling.

5. Compare the subcooling value with those shown in Table 6. If subcooling is greater than shown, recover some refrigerant. If subcooling is less than shown, add some refrigerant.

Subcooling Values for TXV Systems									
SUBCOOLING VALUES FOR TXV SYSTEMS									
OUTDOOR TEMP.°F	LIQUID SUBCOOLING (±1°F)								
	-18	-24	-30	-36	-41	-42	-47	-48	-60
65	10	10	10	11	9	10	6	8	8
75	6	8	8	11	7	7	6	8	7
85	6	8	7	11	7	7	6	8	8
95	6	8	7	10	7	7	6	8	7
105	6	8	7	10	7	7	6	8	7
115	6	8	6	9	6	7	5	7	6

Table 6

**Charge Using Approach Method –
Outdoor Temperatures 65°F or Above**

The following procedure is intended as a general guide and is for use on expansion valve systems only. For best results, indoor temperature should 70°F to 80°F. Monitor system pressures while charging.

1. Record outdoor ambient temperature using a digital thermometer.
2. Attach high pressure gauge set and operate unit for several minutes to allow system pressures to stabilize.
3. Compare stabilized pressures with those provided in Table 8. Minor variations in these pressures may be expected due to differences in installations. **Significant differences could mean that the system is not properly charged or that a problem exists with some component in the system.** Pressures higher than those listed indicate that the system is overcharged. Pressures lower than those listed indicate that the system is undercharged. Verify adjusted charge using the approach method.

4. Use the same digital thermometer to check liquid line temperature.
5. Subtract the outdoor ambient temperature from the liquid
 - _____ ° Liquid Line Temperature °F
 - _____ ° Outdoor Ambient Temperature °F
 - = _____ ° Approach Temperature °F
 line temperature to determine the approach temperature.
6. Compare the approach value with those shown in Table 7. If the values do not agree with those provided in Table 7, add refrigerant to lower the approach temperature or recover refrigerant from the system to increase the approach temperature.

Approach Values for TXV Systems									
Model	-18	-24	-30	-36	-41	-42	-47	-48	-60
Temp. °F	6	6	6	6	4	8	8	8	9

Approach value is the liquid line temperature minus the outdoor ambient temperature (±1°F).

NOTE: For best results, use the same digital thermometer to check both outdoor ambient and liquid temperatures.

Table 7

Check Charge Using Normal Operating Pressures

Use Table 8 to perform maintenance checks. Table 8 is not a procedure for charging the system. Minor variations in these pressures may be due to differences in installations. Significant deviations could mean that the system is not properly charged or that a problem exists with some component in the system.

Normal Operating Pressures

Normal Operating Pressures																		
Expansion Valve (TXV)																		
Outdoor Coil Entering Air Temp. °F	-18		-24		-30		-36		-41		-42		-47		-48		-60	
	L	S	L	S	L	S	L	S	L	S	L	S	L	S	L	S	L	S
65	222	140	233	138	230	136	240	137	233	142	236	138	233	139	238	136	239	133
75	259	143	271	140	265	139	278	139	256	143	273	141	272	141	277	139	278	136
85	301	145	313	143	308	141	321	140	299	145	318	143	315	142	320	139	323	138
95	346	146	361	145	355	144	368	142	343	146	366	146	361	144	369	141	370	140
105	396	148	412	147	405	146	419	144	389	148	417	148	413	145	422	144	415	143
115	451	151	468	149	461	148	477	146	452	151	475	151	465	148	481	148	476	147

L = Liquid S = Suction

Values provided above are typical pressures. Indoor unit matchup, indoor air quality, and indoor load will cause pressures to vary.

Table 8

OPERATION

Outdoor unit and indoor blower cycle on demand from the room thermostat. When the thermostat blower switch is moved to the ON position, the indoor blower operates continuously.

MAINTENANCE



Before performing maintenance operations on system, turn the electric power to unit OFF at disconnect switch(es). Unit may have multiple power supplies. Electrical shock could cause personal injury or death.

Maintenance and service must be performed by a qualified installer or service agency.

At the beginning of each cooling season, the system should be checked as follows:

1. Clean and inspect condenser coil. Coil may be flushed with a water hose. Be sure the power is off before using water to clean the coil.
2. Outdoor fan motor is pre-lubricated and sealed. No further lubrication is needed.
3. Visually inspect connecting lines and coils for evidence of oil leaks.
4. Check wiring for loose connections.
5. Check for correct voltage at unit (with unit operating).
6. Check amp-draw outdoor fan motor.

Unit nameplate _____ Actual _____

NOTE – If owner complains of insufficient cooling, the unit should be gauged and refrigerant charge checked. Refer to the Refrigerant Charging section on page 12.

Indoor Coil

1. Clean coil, if necessary.
2. Check connecting lines and coils for evidence of oil leaks.
3. Check condensate pan line and clean, if necessary.

Indoor Unit

1. Clean or change filters.
2. Adjust blower speed for cooling. Measure the pressure drop over the coil to determine the correct blower CFM.
3. Belt drive blowers: Check belt for wear and proper tension.

4. Check all wiring for loose connections.
5. Check for correct voltage at unit (with unit operating).
6. Check amp-draw on blower motor.

Unit nameplate _____ Actual _____

Start-Up and Performance Checklist

Job Name _____ Job No. _____ Date _____

Job Location _____ City _____ State _____

Installer _____ City _____ State _____

Unit Model No. _____ Serial No. _____

Service Technician _____ Nameplate Voltage _____

Rated Load Ampacity _____ Compressor _____ Outdoor Fan _____

Maximum Fuse or Circuit Breaker _____

Electrical Connections Tight? Indoor Filter Clean? Supply Voltage (Unit Off) _____

Indoor Blower RPM _____ S.P. Drop Over Indoor (Dry) _____

Outdoor Coil Entering Air Temperature _____ Voltage with Compressor Operating _____

Discharge Pressure _____ Vapor Pressure _____

Refrigerant Charge Checked? Outdoor Fan Checked?

Refrigerant Lines: Leak Checked? Properly Insulated?

Service Valves: Fully Opened? Caps Tight?

Thermostat: Calibrated? Properly Set? Level?

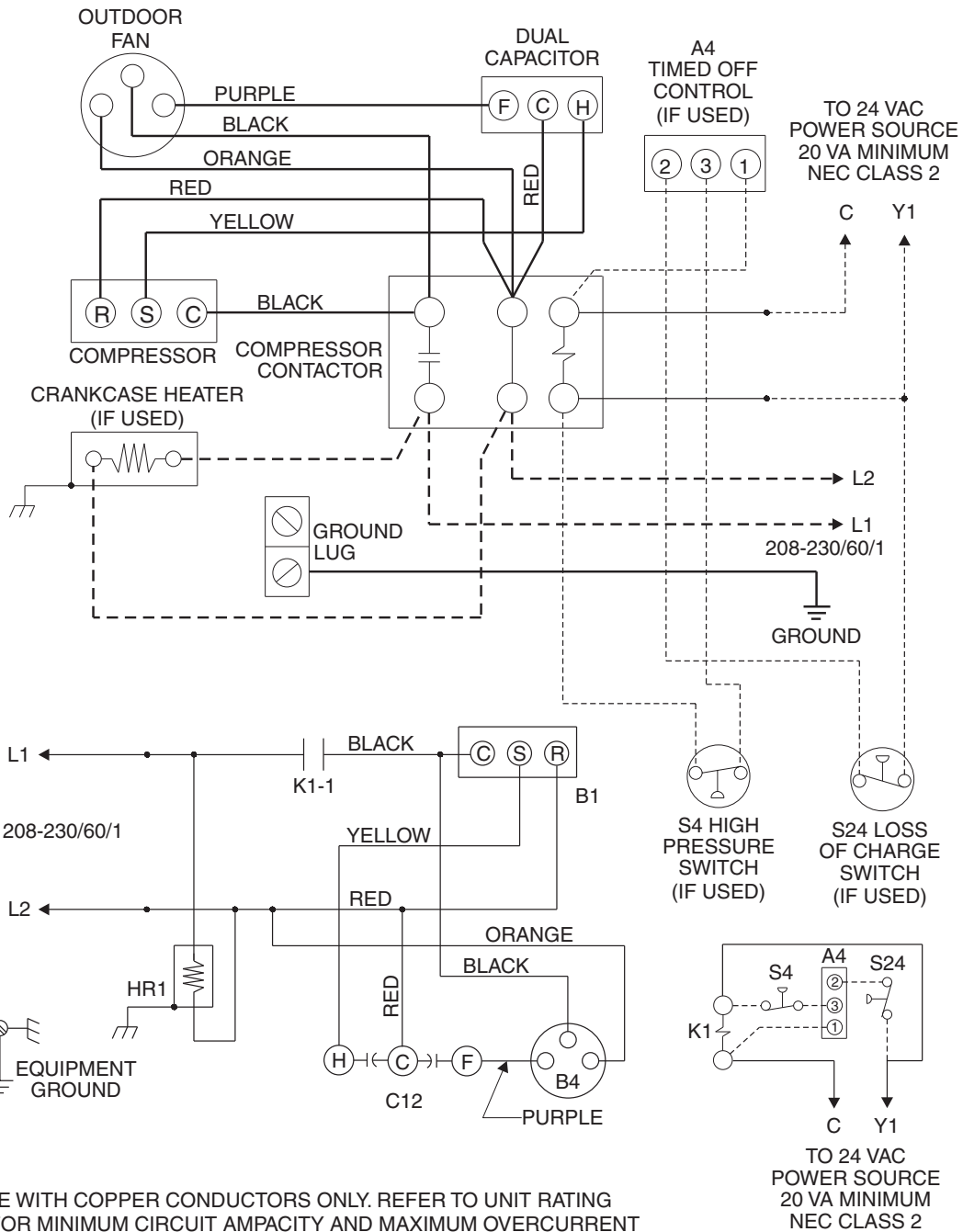

1 FOR USE WITH COPPER CONDUCTORS ONLY. REFER TO UNIT RATING PLATE FOR MINIMUM CIRCUIT AMPACITY AND MAXIMUM OVERCURRENT PROTECTION SIZE.

WARNING--
ELECTRIC SHOCK HAZARD, CAN CAUSE INJURY OR DEATH.
UNIT MUST BE GROUNDED IN ACCORDANCE WITH NATIONAL AND LOCAL CODES.

- LINE VOLTAGE FACTORY INSTALLED
- LINE VOLTAGE FIELD INSTALLED
- 24 VOLT FACTORY INSTALLED
- CLASS II VOLTAGE FIELD INSTALLED

DESCRIPTION	
KEY	COMPONENT
A4	CONTROL - TIMED OFF
B1	COMPRESSOR
B4	MOTOR - OUTDOOR FAN
C12	CAPACITOR - DUAL
HR1	HEATER - COMPRESSOR
K1-1	CONTACTOR - COMPRESSOR
S4	SWITCH - HIGH PRESSURE
S24	SWITCH - LOSS OF CHARGE

Wiring Diagram P/N 48352-001

Figure 12

**ALLIED AIR ENTERPRISES
EQUIPMENT LIMITED WARRANTY
APPLIES IN U.S.A. AND CANADA ONLY
FAILURE TO MAINTAIN YOUR EQUIPMENT WILL VOID THIS WARRANTY**

COVERED EQUIPMENT

The following Allied Air Enterprises heating and cooling equipment is covered by the Limited Warranty,

Condensing Units: 2SCU13, 4SCU13, 4SCU14, 4SCU16, 4SCU18, 2AC13, 2AC14, 4AC13, 4AC14

Heat Pumps: 2SHP13, 4SHP13, 2SHP14, 4SHP14, 4SHP16, 4SHP18, 2HP13, 2HP14, 4HP13, 4HP14

Gas Furnaces: G1N80, G1D80, G2D80, G1D91, G1D93, G2D93, G2D95, FPBB, CG80, CG90, CG92, CG93, CG95

Oil Furnaces: LBR80, LBF80, LHF80, LUF80, LHR80, RLUF, RLB, RLBR, RLBU, RLHF, RLHR

Electric Furnaces: EFC, EFV

Evaporator Coils: EC, EU, EH, EM

Air handlers: BCS2, RBCS2

Package Equipment: 2PCE13, 4PCE13, 4PCE15, 2PGE13, 4PGE13, 4PGE15, 2PHP13, 4PHP13, 4PHP15, 2SG13, 2SH13, 2SA13, RGE13, RPGE13, RHP13, RCE13, RPHP13, RPCE13

PARTS and COMPRESSOR COVERAGE

The covered equipment, parts and compressor are warranted by Allied Air for a period of five (5) years from the date of the original installation, when installed in a residential application (which includes homes, duplexes, apartments and condominiums). For non-residential applications, the covered equipment and parts are warranted for a period of one (1) year and compressor is warranted for five (5) years from the date of the original installation. If, during this period, a covered component fails because of a manufacturing defect, Allied Air will provide a free replacement part to the owner through a licensed service contractor utilizing an Allied Air distributor. The purchaser must pay shipping charges and all other costs of warranty service. Allied Air will not pay labor involved in diagnostic calls or in removing, repairing, servicing or replacing parts. Such cost may be covered by a separate warranty provided by the installer.

HEAT EXCHANGER EXTENDED COVERAGE

All covered heat exchangers are warranted by Allied Air for a period of twenty (20) years from the date of original installation, when installed in a residential application. Heat exchangers in all non-residential applications are warranted for a period of ten (10) years.

Heat Exchanger Availability: If a replacement heat exchanger is no longer available for a unit covered by this Limited Warranty, Allied Air will allow a credit toward the purchase of an equivalent Allied Air furnace (at the current suggested distributor's cost).

NOTE: If the date of original installation cannot be verified, the warranty period will be deemed to begin ninety (90) days after the date of manufacture.

EXCLUDED COMPONENTS

The following components are expressly not covered by this Limited Warranty: cabinets, cabinet pieces, air filters, driers, refrigerant, refrigerant line sets, belts, wiring, fuses, oil nozzles, unit accessories and any parts not affecting unit operation

CARE OF EQUIPMENT

All new Allied Air units must be properly installed, operated and maintained in accordance with the unit installation, operation and maintenance instructions provided with each Allied Air unit. Failure to maintain the equipment per Allied Air instructions will void this Limited Warranty.

WARRANTY PROCEDURE

When service or warranty parts are required:

1. Call a local licensed service dealer or contractor.
2. If the installing dealer is unable to provide warranty service, check online at www.alliedair.com.
3. Be prepared to furnish the following information:
 - a. complete model and serial number;
 - b. proof of required periodic maintenance, installation date and location; and
 - c. an accurate description of the problem.

WARRANTY LIMITATIONS

1. This Limited Warranty is void if the covered equipment is removed from the original installation site.
2. This Limited Warranty does not cover damage or defect resulting from:
 - a. flood, wind, fire, lightning, mold, or installation and operation in a corrosive atmosphere, or otherwise in contact with corrosive materials (chlorine, fluorine, salt, recycled waste water, urine, fertilizers, or other damaging substances or chemicals); accident, or neglect or unreasonable use or operation of the equipment including operation of electrical equipment at voltages other than the range specified on the unit nameplate (includes damages caused by brownouts);
 - b. modification, change or alteration of the equipment, except as directed in writing by Allied Air;
 - c. operation with system components (indoor unit, outdoor unit and refrigerant control devices) which are not an ARI match or meet the specifications recommended by Allied Air;
 - d. operation of furnaces with return air temperatures of less than 60°F (16°C) or operation of a furnace field installed downstream from a cooling coil; and
 - e. use of contaminated refrigerant or refrigerant not compatible with the unit.

The installation of replacement parts under the terms of this Limited Warranty does not extend the original warranty period.

Allied Air makes no express warranties other than the Limited Warranty specified above. All implied warranties, including the implied warranties of merchantability and fitness for a particular purpose, are excluded to the extent legally permissible. Should such exclusion or limitation of this Limited Warranty be unenforceable, such implied warranties are in any event limited to a period of one (1) year. Liability for incidental and consequential damages is excluded. Some states do not allow limitation of incidental damages, so these limitations or exclusions may not apply to you. Allied Air will not pay electricity or fuel costs, or increases in electricity or fuel costs, for any reason whatsoever, including additional or unusual use of supplemental electric heat. This Limited Warranty does not cover lodging expenses or labor charges.

Allied Air shall not be liable for any default or delay in performance under this Limited Warranty caused by any contingency beyond its control.

This Limited Warranty gives you specific legal rights, and you may also have other rights which vary from state to state.

NOTE TO CUSTOMER:

Please complete information below and retain this warranty for your records and future reference.

Outside Unit Model Number: _____ Serial Number: _____ Installed Date: _____

Furnace / Air Handler: _____ Serial Number: _____ Installed Date: _____

Indoor Coil Model Number: _____ Serial Number: _____ Installed Dare: _____

Installing Company Name: _____ Phone: _____

Installing Company Address: _____ State/Province: _____ Zip/Postal Code: _____



215 Metropolitan Drive - West Columbia - SC - 29170

© 2008 Allied Air Enterprises Litho U.S.A. FORM W-2008-2 (9/25/2009)

5-YEAR LIMITED EXTENDED PARTS WARRANTY

Allied Air Enterprises Inc. ("Allied Air") provides its air conditioning and heating products with a Standard Limited Parts Warranty for five (5) years. This additional 5-Year Limited Extended Parts Warranty is in addition to and is intended to supplement Allied Air's Standard Limited Parts Warranty. As such, Allied Air provides for a total of 10-years of limited warranty coverage (Standard Limited Parts Warranty plus additional 5-Year Limited Extended Parts Warranty).

This 5-Year Limited Extended Parts Warranty applies only to the original purchaser of the equipment and cannot be transferred. If during the coverage period, a covered part fails because of a defect in materials or workmanship under normal use and maintenance, Allied Air will provide a free replacement part to the purchaser through a licensed service contractor utilizing an authorized Allied Air distributor. The purchaser must pay shipping costs and all other costs of warranty service. Allied Air will not pay labor involved in diagnostic calls or in removing, repairing, servicing or replacing parts.

EXTENDED COVERAGE -

PARTS/COMPRESSORS

Covered equipment and parts are warranted by Allied Air for a total of **10 YEARS** (Standard Limited Parts Warranty) from installation, except as provided below

HEAT EXCHANGERS

Covered residential heating equipment's heat exchanger is warranted by Allied Air for a LIMITED LIFETIME from date of original installation, except as provided below.

EXCLUDED COMPONENTS -

The following components are expressly not covered by this 5-Year Limited Extended Parts Warranty: cabinets, cabinet pieces, air filters, driers, refrigerant, refrigerant line sets, belts, wiring, fuses, oil nozzles, unit accessories, R-22 compressors, and any parts not affecting unit operation.

REQUIREMENTS FOR EXTENDED COVERAGE-

1. The unit is an Armstrong Air, Air ease, Ducane, or Concord branded unit;
2. The unit is installed in a residential application, which is an owner-occupied single-family residence. No commercial applications are allowed;
3. **The unit is properly registered at www.alliedair.com with Allied Air within 60-days after the original date of installation or occupancy.¹ To register, follow the directions and complete the online warranty registration at www.alliedair.com. For customer inquiries, contact Allied Air at 1-800-448-5872.**
4. The unit is part of a complete ARI matched system and installed by a state certified or licensed contractor in accordance with the unit installation, operation, and maintenance instructions provided with the unit.
5. Coils and air handlers are covered only when they are branded Armstrong, AirEase, Ducane, Concord or ADP and are purchased and newly installed as a system along with a qualifying unit. Except for ADP-branded products, coverage of other third party coils and air handlers are specifically excluded from this 5-Year Limited Extended Parts Warranty.
6. Installation of the unit takes place on or after October 3, 2008.

If this 5-Year Limited Extended Warranty does not apply, then parts are warranted under the Standard Limited Parts Warranty for a period of **5 YEARS** and heat exchangers for **20 YEARS**. If the Standard Limited Parts Warranty periods differ from the original warranty certificate, the periods stated on the original warranty certificate apply.

This 5-Year Limited Extended Parts Warranty does not apply to, and no warranty is offered by Allied Air, on any unit ordered over the internet. Proof of purchase may be required.

Any part replaced pursuant to this 5-Year Limited Extended Parts Warranty is warranted only for the unexpired portion of the limited extended warranty term remaining for the original part. The installation of replacement parts under the terms of this 5-Year Limited Extended Parts Warranty does not extend the warranty period.

Steps for obtaining replacement parts under this 5-Year Limited Extended Parts Warranty:

If you suspect a defect in your equipment, please contact the installer of the unit to obtain assistance. If unsuccessful, please contact an Allied Air dealer or distributor in your area. If unable to obtain local assistance, refer to Allied Air's website (www.alliedair.com) or contact Allied Air at 800-448-5872.

Allied Air is specifically not responsible for:

1. Damage or repairs required as a result of flood, fire, wind, lightning strike (to the home or unit), corrosive atmosphere, contact with corrosive material (chlorine, fluorine, salt, recycled waste water, fertilizers or other damaging substances) or other conditions beyond the control of Allied Air;
2. Use of parts, accessories, or refrigerant not compatible with the unit;
3. Modification, change or alteration of the unit, except as expressly directed in writing by Allied Air;
4. Improper use, accident, neglect or unreasonable use or operation of the unit, including operation of electrical equipment at voltages other than the range specified on the unit nameplate;
5. Operation with system parts (indoor unit, outdoor unit and refrigerant control devices) which are not ARI matched or do not meet the specifications recommended by Allied Air;
6. Damage or repairs required as a consequence of faulty or installation or application;
7. Normal maintenance as described in the installation and operating manual, such as cleaning of coils, filter cleaning and/or replacement and lubrication; and
8. Changes in the appearance or sound of the unit that do not affect its performance.

This 5-Year Limited Extended Parts Warranty is an extension of Allied Air's Standard Limited Parts Warranty. **ANY IMPLIED WARRANTY OF MERCHANTABILITY OR FITNESS FOR A PARTICULAR PURPOSE ON THIS PRODUCT IS LIMITED IN DURATION TO THE TERM OF THIS LIMITED EXTENDED WARRANTY.** Some states and provinces do not allow limitations on how long an implied warranty lasts, so the above limitation may not apply to you.

ALLIED AIR SHALL IN NO EVENT BE LIABLE FOR INCIDENTAL OR CONSEQUENTIAL DAMAGES, INCLUDING BUT NOT LIMITED TO EXTRA UTILITY EXPENSES OR DAMAGES TO PROPERTY. Some states and provinces do not allow the exclusion or limitation of incidental or consequential damages, so the above limitation or exclusion may not apply to you

The parties intend this writing as a final expression of their agreement with respect to warranties. Allied Air makes no other warranty beyond that which is expressly contained in this writing.

Allied Air shall not be liable for any default or delay in performance under this warranty caused by any contingency beyond its control, including the unavailability of replacement parts.

This warranty gives you specific legal rights, and you may also have other rights that vary from state to state or province to province.

¹ Excludes residents of states or provinces where registration requirements are prohibited, such as California and Quebec. Residents of these states or provinces may either register as noted above or provide proof of when the unit was purchased and installed, such as an original invoice from the contractor with the Owner's name, address, purchase date, serial and model number.